

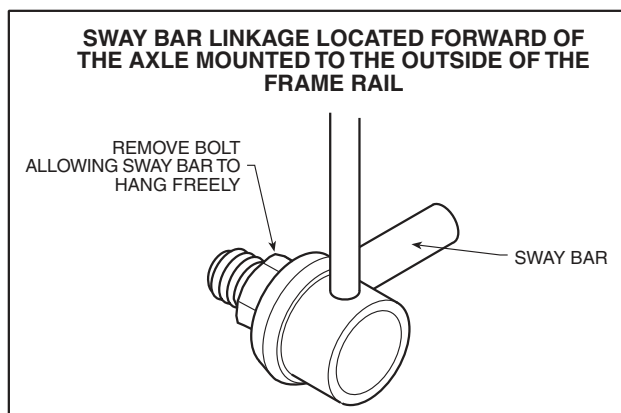

Firestone
 RIDE-RITE® - COIL-RITE® - SPORT-RITE™
 World's Number 1 Air Spring

INSTALLATION INSTRUCTIONS

Read installation instructions in its entirety before installing your Coil-Rite Kit



WARNING

Do not inflate this assembly when it is unrestricted. The assembly must be restricted by a coil spring. Do not inflate beyond recommended operating pressures for your specific vehicle. Improper use or over inflation may cause property damage or severe personal injury.

FIRESTONE INDUSTRIAL PRODUCTS
 CARMEL, INDIANA, USA

NOTE:

This kit is intended to fit 1998 and newer Toyota Land Cruisers and 4-Runners.

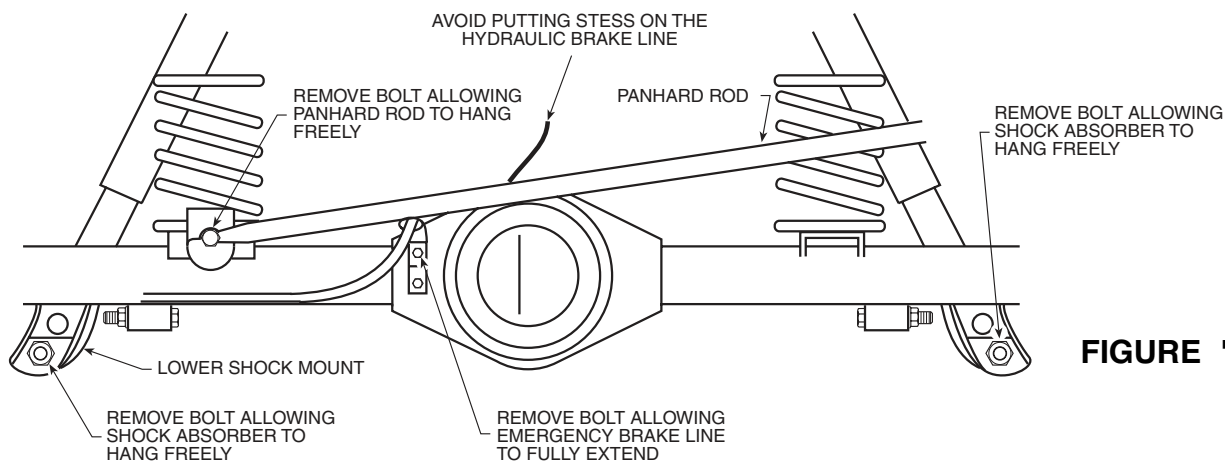

FIGURE "A"

RECOMMENDED OPERATING PRESSURES

SUV's	5 - 35 p.s.i.
-------	---------------

PARTS LIST

DESCRIPTION	QTY.
AIR SPRINGS 4.75" X 7.50"	2
PLUG	1
18' AIR LINE	1
NYLON TIE	6
PUSH-TO-CONNECT INFLATION VALVE	2
5/16" FLAT WASHER	4
THERMAL SLEEVE	2

STEP 1 - VEHICLE PREPARATION

With the vehicle on a solid level surface chock the front wheels. Disconnect the negative battery cable. Raise the rear wheels of the vehicle using a lift or platform jack rated for your vehicle's weight at the center of the rear axle. Continue to raise the vehicle until the rear wheels are 8" off the ground. Lower the vehicle frame forward of the suspension onto jack stands rated for your vehicle's weight allowing the suspension to hang freely. (DO NOT use wood or concrete blocks to support the weight of the vehicle.)

In order to complete the installation of the air helper springs, it is necessary to remove the coil springs from the vehicle. With the vehicle resting on jack stands, jack the vehicle suspension from the differential up approximately 2" from its fully extended position. Remove the lower shock bolt and free the shock from both sides

COIL-RITE INSTALLATION PROCEDURE

of the vehicle *see Figure "A"*. Then, detach the sway bar on both sides of the vehicle located forward of the axle mounted to the frame rail *see Figure "A"*. Now, remove the emergency brake cable clip located on the rear center of the axle allowing the emergency brake line to hang freely *see Figure "A"*. The panhard rod must be unbolted on the drivers side rear of the axle in order to lower the suspension to free the coil springs *see Figure "A"*. To remove the coil springs place a jack stand under the passenger side axle (leave the current jack stands under the frame in place) as close to the wheel as possible. Then lower the jack under the differential allowing the drivers side suspension to hang freely. Take special precautions not to overextend the the flexible hydraulic barke line *see Figure "A"*. Remove the driver's side coil spring and rubber overload bumper.

STEP 2 - OVERLOAD BUMPER PREPARATION

To provide enough operating distance for the air helper spring the existing overload bumper must be modified. After removal of the overload bumper the four (4) convoluted sections of the bumper should be cut off. This is accomplished by holding the largest portion of the bumper in a vice and using a hack saw to remove the upper portion of the overload bumper *see Figure "B"*. As a helpful hint use glass cleaner to lubricate the saw blade for easier cutting. The lower convoluted portion of the overload bumper will not be used. The upper portion will be needed to complete this installation *see Figure "B"*.

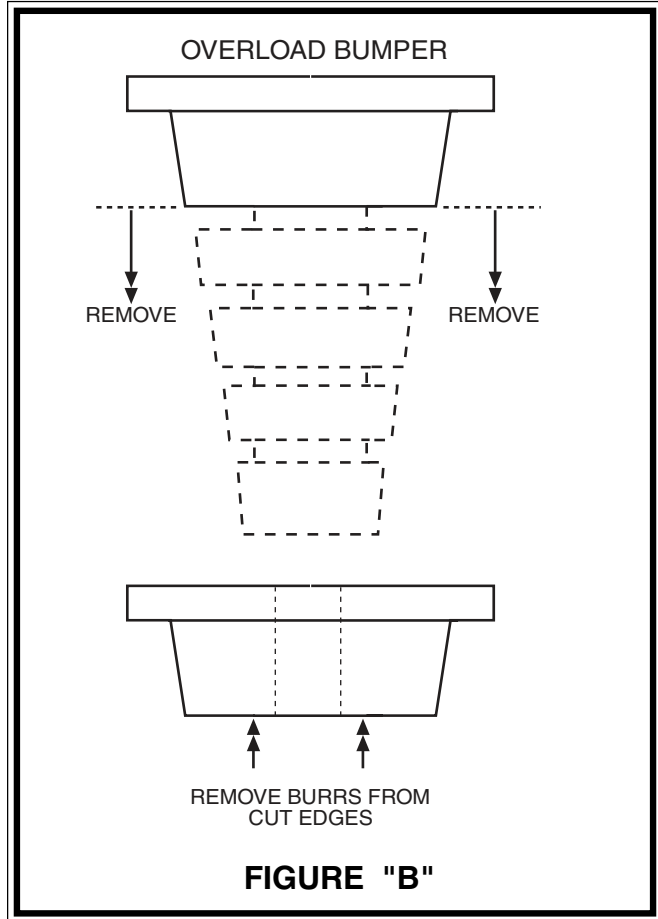

STEP 3 - INSTALL THE AIR SPRING

Insert the air helper spring into the driver's side coil spring with the air inlet towards the top of the coil spring *see Figure "C"*. Cut the air line tubing into two equal lengths, making sure the tubing is cut as squarely as possible (a "saw" cut with a sharp knife is preferred). Insert the air line tubing into the push-to-connect fitting on the air spring as far as possible.

STEP 4 - RE-INSTALL THE OVERLOAD BUMPER

After the air spring has been installed into the coil spring place the converted overload bumper back in its original position on top of the coil spring with the air line routed through the hole in the center *see Figure "C"*. The top of the air spring will be next to the bottom of the overload bumper. The coil spring will be re-installed after the air line has been inserted through the upper spring seat and installed in the air spring refer to the following step. Make sure that the bottom of the spring is seated in the spring retainer properly. Route the air line tubing through the top of the upper spring seat and through the hole in the overload bumper *see Figure "C"*.

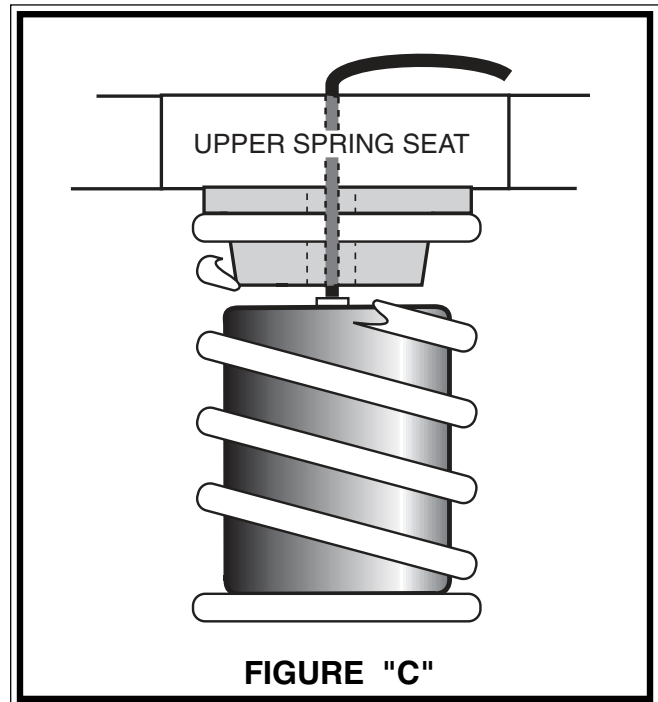

COIL-RITE INSTALLATION PROCEDURE

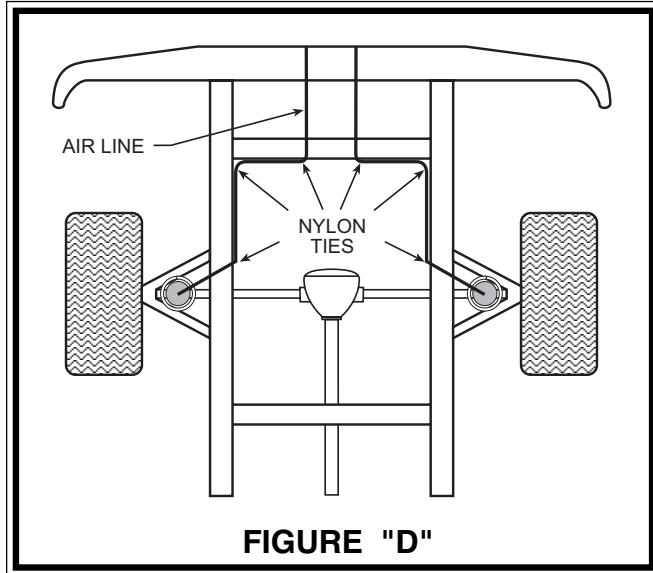

FIGURE "D"

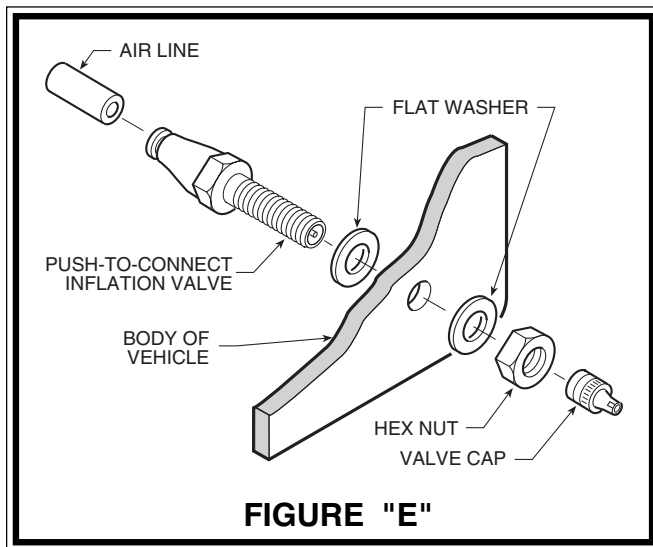

FIGURE "E"

FORBESTRIDE use only enough air pressure in the air helper springs to level the vehicle when viewed from the side (front to rear). This amount will vary depending on the load, location of load, condition of existing suspension and personal preference.

STEP 5 - ROUTE THE AIR LINE

Route the air line from the air spring to the desired inflation valve location. Do not fold or kink the air line tubing.

With the tubing routed from the air spring to the inflation valve location, use the nylon ties supplied to secure the air line tubing to the vehicle *see Figure "D"*. Be careful to avoid heat and sharp edges when fastening the tubing to the vehicle. Route the tubing away from the exhaust system.

STEP 6 - INSTALL THE INFLATION VALVE

Drill a 5/16" hole where you wish to mount the inflation valve. Remember to keep the inflation valve in a protected area that is easily accessible. Attach the inflation valve to the bumper or body of the vehicle *see Figure "E"*.

Cut the excess air line tubing so that it will fit easily into the inflation valve, making sure the end is cut squarely (a "saw" cut with a sharp knife is preferred). Push the end of the tubing into the inflation valve as far as possible.

STEP 7 - INSTALL THE OPPOSITE-SIDE

AIR SPRING

Follow Steps 2-6 to install the second air spring on the remaining side of the vehicle. Note: Raise the axle by the differential approximately 2" and remove the jack stand under the axle on the passenger side and place under the drivers side of the vehicle. Lower the jack and allow the suspension to hang freely for installation on the passenger's side. Be sure not to over extend the brake line.

STEP 8 - COMPLETION

This now completes the installation. Jack the vehicle up approximately 2" under the differential and remove the jack stand from under the axle. Reattach the panhard rod, emergency brake cable clip, sway bar links, and shocks. Inflate the air springs to 10 - 15 psi. Torque fasteners to manufacturers specifications. Raise the vehicle and remove the jack stands from under the frame and lower the vehicle to the ground. Re-attach the negative battery cable. Remove the wheel chocks from the front wheels.

STEP 9 - INFLATE AND TEST

Check the recommended inflation pressure and inflate the air springs to recommended maximum operating pressure (see page 1 for operating pressures). With a soap and water solution, check for air leaks around the fittings and valve core. We recommend inflating and deflating in 5 p.s.i. increments to find the ideal riding condition for your vehicle.

NOTE: CHECK AIR PRESSURE ON A MONTHLY BASIS.

**FOR MORE INFORMATION OR
TECHNICAL ASSISTANCE CALL:
1-800-247-4337**

Firestone
RIDE-RITE® - COIL-RITE® - SPORT-RITE™
World's Number 1 Air Spring

FIRESTONE INDUSTRIAL PRODUCTS
12650 HAMILTON CROSSING BOULEVARD
CARMEL, IN 46032

TELEPHONE: 317-818-8600
1-800-247-4337
FAX: 317-818-8645

www.ride-rite.com